

# CL Challenger Lifts



**Versymmetric®**  
**Plus**

**Model#: CL10V3-2-DPC**

Versymmetric® Plus 2-Post Lift  
Dual Pendant Power Controls  
Offset 3-stage front + 3-stage rear arms  
Asymmetric application  
10,000 lb. capacity  
(shown with optional accessories)



## CL10series

Service more vehicles and make more money with the **Versymmetric®** and **Versymmetric® Plus** CL10series two post automotive lifts. Its exclusive Versymmetric® Technology provides the versatility to safely lift vehicles symmetrically or asymmetrically within the same service bay.

With three Versymmetric® productivity configurations - **Max Plus Productivity**, **Maximum Productivity** and **Complete Productivity**, adjustable height and width options, and custom color options, CL10series two post automotive lifts are the best choice for professional service facilities.

Other standard features include double telescoping screw pads, Heavy-Duty pulley and cable equalization system, elongated carriage, rubber door guards, adjustable arm restraint shafts, single point mechanical lock release and padded overhead shut off system.

## Features & Benefits:

- Exclusive **Versymmetric® Technology** provides a versatile **2 Lifts in One™** Design to safely lift vehicles symmetrically or asymmetrically within the same service bay
- CL10series two post lifts available in three **Versymmetric®** Productivity Configurations:
  - » **Max Plus Productivity** (CL10V3DPC) - Dual Pendant Power Controls, Stack Adapter Kit and Document Caddy with Versymmetric® Plus offset 3-stage front + 3-stage rear arms
  - » **Maximum Productivity** (CL10V3) - Conventional Power Controls, Versymmetric® Plus offset 3-stage front + 3-stage rear arms
  - » **Complete Productivity** (CL10) - Conventional Power Controls, Versymmetric® offset 2-stage front and rear arms
- Adjustable arm restraint shafts compensate for uneven floors
- Grease fittings located on arm pin bushings minimize corrosion to keep arms swinging freely
- Double Telescoping Screw Pads adjust to multiple heights minimizing the need for adapters
- Rubber door guards protect vehicles from door damage when accessing driver controls
- 48" elongated carriage design decreases load on bearing
- Heavy-Duty 5" diameter pulley and 5/16" cable reduces stress on equalization system and increases cable life
- Fully gusseted base plate design reduces column deflection
- 11' 8" standard height allows lift to be placed in standard service bay with 12' ceiling
- Available 2' and 3' column extensions enable technician to work at an ergonomic height when servicing taller vehicles
- Padded overhead shut off system prevents vehicle damage from being raised too high
- Single-point mechanical lock release system allows technician to disengage both column locks simultaneously
- Many accessories available - reference the Challenger Lifts **Versymmetric® 2-Post Accessories** sheet for details



10315 Stack Adapter kit comes standard with CL10V3-DPC models (sold as optional accessory with other CL10 models)

large 5" pulley diameter versus competition



rubber door guard protection

double telescoping screw adjusts from 3-7/8" to 7-1/8", removable rubber pad for frame contact



48" carriage with (8) slide bearing blocks reduce stress

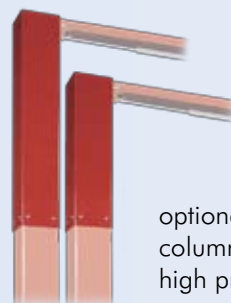

optional 2' or 3' column extensions for high profile vehicles



gusseted base plate requires a minimum of 4" concrete at 3500 psi

**CL10series**

## Arm Configurations

Complete Productivity



### CL10:

- » Offset 2-stage front arms
- » Wide arm sweep, retraction and reach meets the recommended lifting points of most vehicles
- » Offset front arm provides single sweep spotting - no rolling vehicles back and forth to swing front arm clear of front tire

Maximum Productivity / Max Plus Productivity

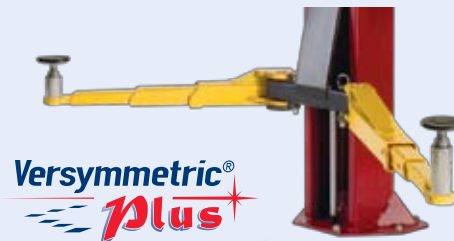

### CL10V3 / CL10V3-DPC:

- » Industry first two post lift with offset 3-stage front arms + 3-stage rear arms
- » Maximum arm sweep, reach and retraction meets the widest range of recommended lifting points
- » Offset front arm provides single sweep spotting - no rolling vehicles back and forth to swing front arm clear of front tire

## Power Control Configurations



### CL10 / CL10V3 - Conventional Controls:

- » Single push button powers lift up
- » Two handed lowering operation - single point mechanical lock release / release valve
- » Single point mechanical lock release system disengages both column locks simultaneously

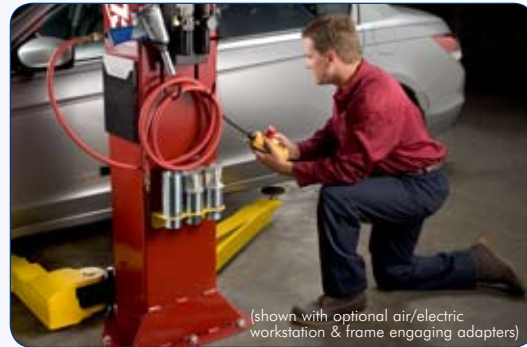

### CL10V3-DPC:

- » Always within technician reach when small spotting adjustments matter the most, dual pendant power controls expedites vehicle spotting by providing an unobstructed view to lifting points
- » OSHA compliant keyed lockout safety button locks out power to the lift
- » Up power button raises lift
- » Down power button / dual single-point mechanical lock release system lowers lift from either column



## Lifting Point Configurations



CL10 / CL10V3 models come standard with double telescoping screw with removable pad.



CL10V3-DPC models come standard with double telescoping screw with removable pad and 10315 Stack Adapter Kit - includes (4) 3" adapters, (2) 6" adapters and (2) organizer racks.



Optional 10318 frame engaging truck adapters can be used with our 3" or 6" stack adapters. Simply take out the screw pad and drop in the stack extension and frame engaging adapter. Frame engaging adapters are made from one piece of cast steel.

Complete Productivity

Maximum Productivity

Max Plus Productivity

Model Number	CL10	CL10-2	CL10-3	CL10V3	CL10V3-2	CL10V3-3	CL10V3-DPC	CL10V3-2-DPC	CL10V3-3-DPC
Lifting Capacity*	10,000 lb. (4535kg)								
A Rise Height <sup>1</sup>	74 <sup>5</sup> / <sub>8</sub> " (1895mm)								
B Column Height	11' 8" (3556mm)	13' 8" (4166mm)	14' 8" (4470mm)	11' 8" (3556mm)	13' 8" (4166mm)	14' 8" (4470mm)	11' 8" (3556mm)	13' 8" (4166mm)	14' 8" (4470mm)
C Cylinder Overall (Full Stroke)	11' 11" (3632mm)								
D Adjustable Width Overall	11' 6 <sup>1</sup> / <sub>2</sub> " / 11' 11" (3518mm / 3632mm)								
E Drive-Thru Clearance <sup>2</sup>	100 <sup>1</sup> / <sub>2</sub> " / 105" (2553mm / 2667mm)								
F Floor to Overhead Switch <sup>2</sup>	11' 2 <sup>1</sup> / <sub>2</sub> " (3416mm)	13' 2 <sup>1</sup> / <sub>2</sub> " (4026mm)	14' 2 <sup>1</sup> / <sub>2</sub> " (4331mm)	11' 2 <sup>1</sup> / <sub>2</sub> " (3416mm)	13' 2 <sup>1</sup> / <sub>2</sub> " (4026mm)	14' 2 <sup>1</sup> / <sub>2</sub> " (4331mm)	11' 2 <sup>1</sup> / <sub>2</sub> " (3416mm)	13' 2 <sup>1</sup> / <sub>2</sub> " (4026mm)	14' 2 <sup>1</sup> / <sub>2</sub> " (4331mm)
G Front Arm Reach (Min./Max.)	Min. 27" / Max. 41" (686mm / 1041mm)			Min. 19 <sup>13</sup> / <sub>16</sub> " / Max. 42" (503mm / 1067mm)					
H Rear Arm Reach (Min./Max.)	Min. 42" / Max. 59" (1067mm / 1499mm)			Min. 37 <sup>5</sup> / <sub>8</sub> " / Max. 60" (956mm / 1524mm)					
I Screw Pad Height <sup>3</sup>	Min. 3 <sup>7</sup> / <sub>8</sub> " - Max. 7 <sup>1</sup> / <sub>8</sub> " (98mm / 181mm)								
J Inside Columns <sup>2</sup>	110" / 114 <sup>1</sup> / <sub>2</sub> " (2794mm / 2908mm)								
K Low Lock Height	12" (305mm) Net Rise								
Motor	2HP								
Voltage	208v-230v (Single Phase Std.) <sup>4</sup>								
Speed of Rise	48 Sec.								
Max. Load Per Arm	2,500 lb. (1134kg)								
Ceiling Height Required	12' (3658mm)	13' 9" (4191mm)	14' 9" (4496mm)	12' (3658mm)	13' 9" (4191mm)	14' 9" (4496mm)	12' (3658mm)	13' 9" (4191mm)	14' 9" (4496mm)

\*Lift capacity ratings are based on loads equally distributed on all four arms. <sup>1</sup> Rise height is measured with adjustable screw pads in highest position. <sup>2</sup> Specifications are listed with lift at maximum width and/or height settings. <sup>3</sup> Specifications are listed without rubber pad, for measurements with rubber pad add 1/4" (6mm). <sup>4</sup> Optional 3 phase electrical also available, please specify at time of order. Standard lift colors are Red and Blue. Optional colors available.

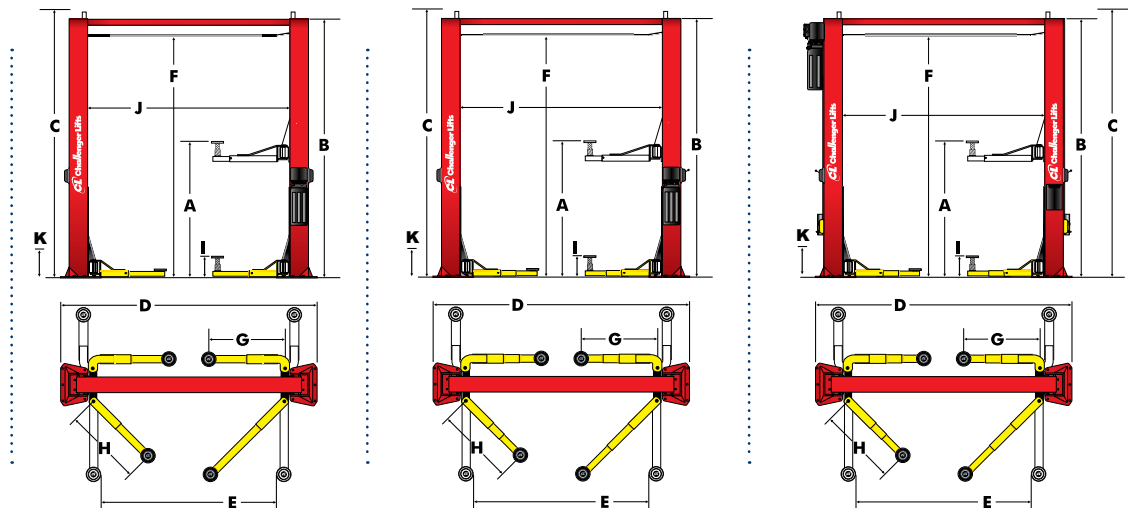

For more information, contact your Authorized Challenger Lifts Distributor:

The Automotive Lift Institute (ALI) certifies that the CL10series described herein complies with the applicable provisions of the American National Standards ANSI/ALI ALCTV 2006 and is Third Party Validated by the ETL Testing Laboratory.



GSA Schedule Contract GS-47F-85900

AAIA Automotive Aftermarket Industry Association

Portage Lift  
4003 Bower Rd.

877-475-4387  
330-325-3309

Rootstown, Ohio 44272

Challenger Lifts, Inc. reserves the right to make changes to specifications without notice and without making changes retroactive. Unloading, installation and oil not included.